



Standard Specification for Surface Discontinuities of Nuts, Inch and Metric Series¹

This standard is issued under the fixed designation F 812/F 812M; the number immediately following the designation indicates the year of original adoption or, in the case of revision, the year of last revision. A number in parentheses indicates the year of last reapproval. A superscript epsilon (ϵ) indicates an editorial change since the last revision or reapproval.

This standard has been approved for use by agencies of the Department of Defense.

1. Scope*

1.1 This specification establishes allowable limits for the various types of surface discontinuities that may occur during the manufacture and processing of metric-series nuts with nominal diameters 5 mm and larger and inch-series nuts with nominal diameters 1/4 in. and larger.

1.2 The values stated in either SI (metric) or inch-pound units are to be regarded separately as standard. The values stated in each system are not exact equivalents; therefore, each system must be used independently of the other. Combining values from the two systems may result in nonconformance with the specification.

1.3 When the engineering requirements of the application necessitate control of surface discontinuities on nuts, the purchaser shall specify conformance to this ASTM specification in the original inquiry and purchase order.

1.3.1 When the engineering requirements of the application necessitate that surface discontinuities on nuts be controlled within limits closer than those specified in this specification, the purchaser shall specify the applicable limits in the original inquiry and purchase order.

1.4 The allowable limits established in this specification for metric nuts, with nominal diameters 5 to 24 mm inclusive, are essentially identical with requirements given in **ISO/DIS 6157/II**. There are no ISO standards for surface discontinuities on metric-series nuts with nominal diameters larger than 24 mm or on any inch-series nuts.

1.5 The following precautionary caveat pertains only to the test method portion, Section 7, of this specification: *This standard does not purport to address all of the safety concerns, if any, associated with its use. It is the responsibility of the user of this standard to establish appropriate safety and health practices and determine the applicability of regulatory limitations prior to use.*

2. Referenced Documents

2.1 *ASTM Standards:*²

F 606 Test Methods for Determining the Mechanical Properties of Externally and Internally Threaded Fasteners, Washers, Direct Tension Indicators, and Rivets

F 606M Test Methods for Determining the Mechanical Properties of Externally and Internally Threaded Fasteners, Washers, and Rivets [Metric]

F 1470 Guide for Fastener Sampling for Specified Mechanical Properties and Performance Inspection

F 1789 Terminology for F16 Mechanical Fasteners

2.2 *ISO Standard:*

ISO/DIS 6157/II Fasteners, Surface Discontinuities on Nuts³

3. Ordering Information

3.1 Orders for nuts requiring surface discontinuity control shall include:

3.1.1 ASTM designation and date of issue of this specification.

3.1.2 Special requirements, for example, closer discontinuity limits (1.3.1) and inspection sampling plan (6.2).

4. Types of Surface Discontinuities (See Standard F 1789 for definitions not provided)

4.1 *Crack:*

4.1.1 *Quench Cracks*—Typical quench cracks are shown in Fig. 1; limits are specified in 5.2.

4.1.2 *Forging Cracks*—Typical forging cracks are shown in Fig. 2; limits are specified in 5.3.

4.1.3 *Inclusion Cracks*—Normally caused by nonmetallic inclusions or stringers inherent in the raw material. Typical inclusion cracks are shown in Fig. 2; limits are specified in 5.3.

¹ This specification is under the jurisdiction of ASTM Committee F16 on Fasteners and is the direct responsibility of Subcommittee F16.93 on Quality Assurance Provisions for Fasteners.

Current edition approved Nov. 15, 2007. Published December 2007. Originally approved in 1983. Last previous edition approved in 2003 as F 812/F 812M – 03.

² For referenced ASTM standards, visit the ASTM website, www.astm.org, or contact ASTM Customer Service at service@astm.org. For *Annual Book of ASTM Standards* volume information, refer to the standard's Document Summary page on the ASTM website.

³ Available from American National Standards Institute (ANSI), 25 W. 43rd St., 4th Floor, New York, NY 10036, <http://www.ansi.org>.

*A Summary of Changes section appears at the end of this standard.

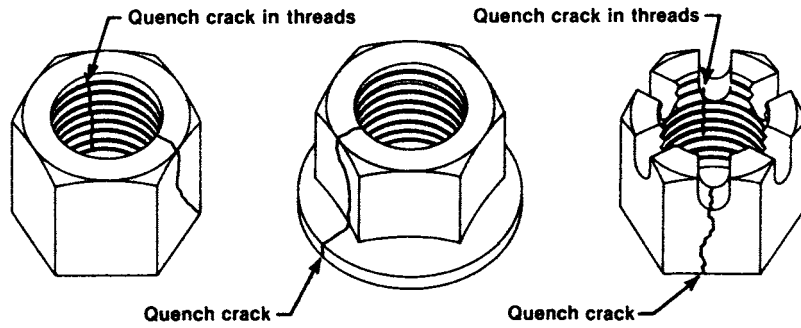

FIG. 1 Typical Quench Cracks in Nuts

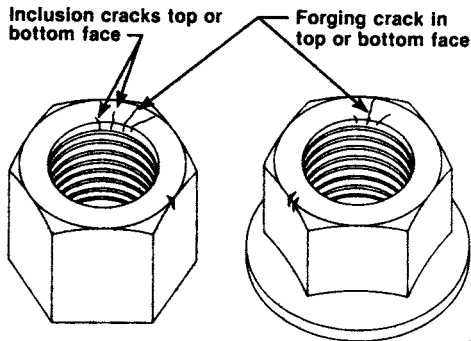

FIG. 2 Typical Forging and Inclusion Cracks in Nuts

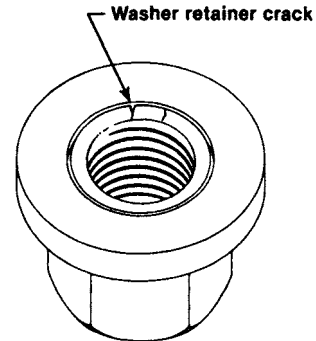

FIG. 4 Typical Washer Retainer Cracks in Nuts

4.1.4 *Locking-Element Cracks*—Occur due to application of pressure when forming the locking element of prevailing torque-type nuts. Such cracks are usually located in the vicinity of the locking element and may be either on the internal or external surface. Typical locking element cracks are shown in Fig. 3; limits are specified in 5.4.

4.1.5 *Washer-Retainer Cracks*—Openings in the lip or hub of metal used to retain a washer on a nut. Washer-retainer cracks may occur when pressure is applied to the lip or hub during assembly of the washer. Typical washer-retainer cracks are shown in Fig. 4; limits are specified in 5.5.

4.2 *Burst*—A typical burst is shown in Fig. 5; limits are specified in 5.6.

4.2.1 *Shear Burst*—A typical shear burst is shown in Fig. 5; limits are specified in 5.6.

4.3 *Seam*—Typical seams are shown in Fig. 6; limits are specified in 5.7.

4.4 *Fold*—Typical folds are shown in Fig. 7; limits are specified in 5.8.

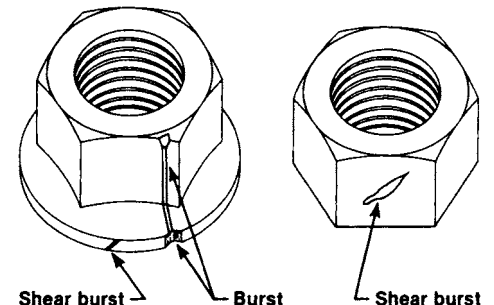

FIG. 5 Typical Bursts and Shear Bursts in Nuts

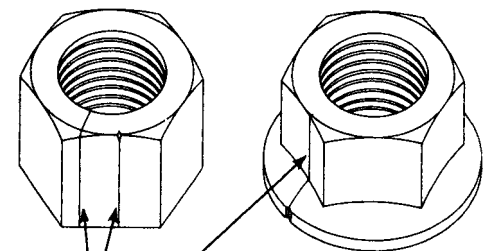

FIG. 6 Typical Seams in Nuts

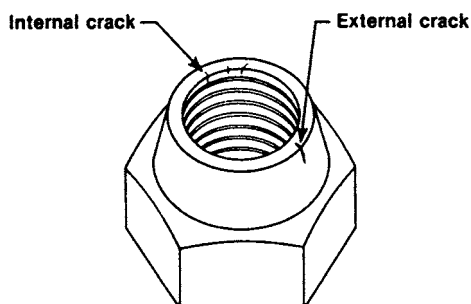

FIG. 3 Typical Locking Element Cracks in Prevailing-Torque Nuts

4.5 *Void*—Voids are produced by marks or impressions of chips (shear burrs) or by rust formation on the raw material. They are not planished during forging. Typical voids are shown in Fig. 8; limits are specified in 5.9.

4.6 *Tool Marks*—Typical tool marks are shown in Fig. 9; limits are specified in 5.10.